



**1/2" WAT-902H2
SUPREME**

**1/3" WAT-902H3
SUPREME**

Super High Sensitivity & High Resolution Monochrome Cameras



Characteristics & functions

- Improved WAT-902H
- Super High sensitivity(Near IR spectrum)
- BNC connector
- Video/DC iris auto-select
- Flickerless mode
- Compact & lightweight
- Shutter speed control
- Electronic iris
- AGC
- Flickerless mode
- Back light compensation
- Video/DC iris auto-select
- Iris level control

Monochrome

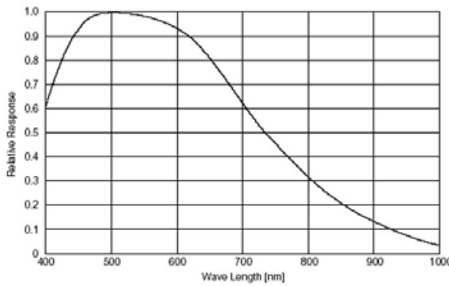

Specifications

Sensor : Sony Ex-View CCD 1/3" (902H3)
CCD 1/2" (902H2)

Effective pixels: 440k (CCIR)

Resolution: 570TVL

Minimum illumination: 0.0003 lx, F1.4

Gain control: AGC (HI:5-50dB, LO:5-32dB)

Back light compensation: ON

S/N ratio: 46dB

Shutter speeds: 1/50s -1/100,000s, FL, OFF

Weight: 90g

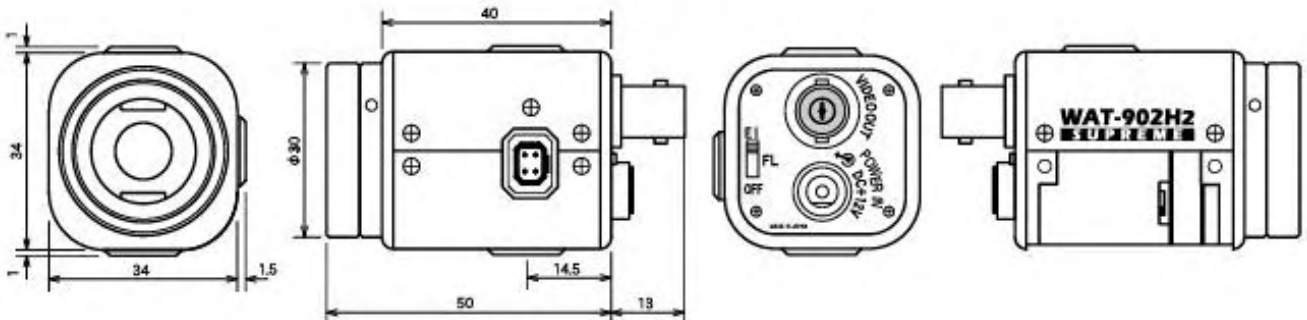

SPECIFICATIONS

Model	WAT-902H2 SUPREME (EIA)	WAT-902H2 SUPREME (CCIR)
Pick-up element	1/2" interline transfer CCD image sensor	
Number of total pixels	811(H) × 508(V)	795(H) × 596(V)
Number of effective pixel	768(H) × 494(V)	752(H) × 582(V)
Unit cell size	8.4μm (H) × 9.8μm (V)	8.6μm (H) × 8.3μm (V)
Shutter speeds	EI: 1/60 sec. - 1/100,000 sec. FL: 1/100 sec. OFF: 1/60 sec.	EI: 1/50 sec. - 1/100,000 sec. FL: 1/120 sec. FL: 1/50 sec.
Minimum illumination	0.0003 lx F1.4 (AGC HI)	

Model	WAT-902H3 SUPREME (EIA)	WAT-902H3 SUPREME (CCIR)
Pick-up element	1/3" interline transfer CCD image sensor	
Number of total pixels	811(H) × 508(V)	795(H) × 596(V)
Number of effective pixel	768(H) × 494(V)	752(H) × 582(V)
Unit cell size	6.35μm (H) × 7.40μm (V)	6.50μm (H) × 6.25μm (V)
Shutter speeds	EI: 1/60 sec. - 1/100,000 sec. FL: 1/100 sec. OFF: 1/60 sec.	EI: 1/50 sec. - 1/100,000 sec. FL: 1/120 sec. FL: 1/50 sec.
Minimum illumination	0.0005 lx F1.4 (AGC HI)	

Common specifications	
Synchronizing system	Internal sync.
Video output	1Vp-p, 75ohms, unbalanced
Resolution (H)	570TVL (Center)
S/N ratio	46dB (AGC OFF)
AGC	HI: 5-50dB, LO: 5-32dB
Back light compensation	ON (Center + lower)
Gamma correction	0.45
Power supply	DC12V±10%
Current	160mA
Operating temperature	-10°C - +40°C
Storage temperature	-30°C - +70°C
Dimensions(W×H×L)	35.5 × 36 × 63 (mm)
Weight	90g

*Design and specifications are subject to change without notice.

DIMENSIONS (mm)

